

MOROOKA EUROPE

HIGH EFFICIENCY IN MOTION



MST110C

Max. Payload 11T.

Rubber Crawler Carrier

**CARRIER for SOFT, SANDY and
ROUGH TERRAIN**



Long and wide rubber crawler to provide low ground pressure as well as stability and excellent traction



Easy Control with HST drive system

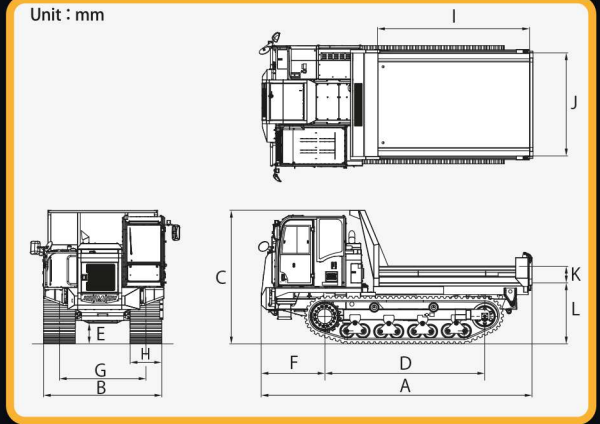

Model		MST110C									
PERFORMANCE				DUMP BODY				TANK CAPACITY			
Maximum Payload	Kg	11,000	Overall Length	I	mm	3,590	Fuel Tank	ℓ	266		
Loading Capacity (Struck)	m ³	3.42	Overall Width	J	mm	2,440	Hydraulic Tank	ℓ	125		
Speed1 Low	Km/h	7.5	Overall Height	K	mm	390	DEF Tank	ℓ	33.54		
Speed2 High	Km/h	10.5	Ground Clearance	L	mm	1,440	DRIVE SYSTEM				
Ground Pressure(empty)	kPa	24.5	ENGINE				HST				
Ground Pressure(Loaded)	kPa	43.5	Model	Cummins QSB6.7-4E Tier 4 final Stage 5			GRADEABILITY				
MACHINE DIMENSION							Fully loaded: 36 % (20 degree) Continuous				
Machine Weight	Kg	14,200	Nominal Output/rpm	HP(kw)/rpm	249,4(186)/2,000		OTHER				
Overall Length	A	mm	Torque	N.m/min-1	1,152/1,500		Cabin (ROPS/FOPS) Joystick control Hardox Dump Body				
Overall Width	B	mm	HYDRAULIC PUMP								
Overall Height	C	mm	Main Pump		2x variable displacement axial piston pump						
Wheelbase	D	mm	Pilot pump		1x gear pump						
Min. Ground Clearance	E	mm	HYDRAULIC MOTOR								
Front Overhang	F	mm	Travel Motor		2x Constant displacement axial piston motors						
Crawler Distance	G	mm									
Crawler Width	H	mm									
Crawler Size		mm									

Remarks: Specification may be changed without any notice.

MOROOKA EUROPE

Im Neugrund 14
64521 Gross-Gerau, Germany
Tel: +49 (0)61529778-0
Fax: +49 (0)61529778-15
Web: www.morookaeurope.com

Contact