

MOROOKA EUROPE

HIGH EFFICIENCY IN MOTION



MST80C

Max. Payload 8T.

Rubber Crawler Carrier

**CARRIER for SOFT, SANDY and
ROUGH TERRAIN**



Long and wide rubber crawler to provide low ground pressure as well as stability and excellent traction



Easy Control with HST drive system

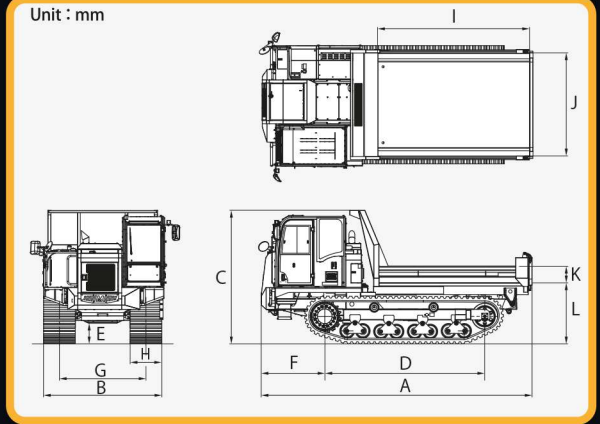

Model		MST80C							
PERFORMANCE				DUMP BODY			TANK CAPACITY		
Maximum Payload	Kg	8,000	Overall Length	I	mm	3,100	Fuel Tank	ℓ	251
Loading Capacity (Struck)	m ³	2.5	Overall Width	J	mm	2,200	Hydraulic Tank	ℓ	125
Speed1 Low	Km/h	6.47	Overall Height	K	mm	370	DEF Tank	ℓ	33.54
Speed2 High	Km/h	9.3	Ground Clearance	L	mm	1,320	DRIVE SYSTEM		
Ground Pressure(empty)	kPa	26.9	ENGINE				HST		
Ground Pressure(Loaded)	kPa	45.5	Model	Cummins B6.7 Tier 4 final Stage 5			GRADEABILITY		
MACHINE DIMENSION							Fully loaded: 36 % (20 degree) Continuous		
Machine Weight	Kg	11,500	Nominal Output/rpm	HP(kw)/rpm	225(168)/2,200		OTHER		
Overall Length	A	mm	Torque	N.m/min-1	1,186/1,800		Cabin (ROPS/FOPS) Air conditioner Joystick control Hardox Dump Body Auto-Deceleration Radio		
Overall Width	B	mm	HYDRAULIC PUMP						
Overall Height	C	mm	Main Pump		2x variable displacement axial piston pump				
Wheelbase	D	mm	Pilot pump		1x gear pump				
Min. Ground Clearance	E	mm	HYDRAULIC MOTOR						
Front Overhang	F	mm	Travel Motor		2x Constant displacement axial piston motors				
Crawler Distance	G	mm							
Crawler Width	H	mm							
Crawler Size		mm							

Remarks: Specification may be changed without any notice.

MOROOKA EUROPE

Im Neugrund 14
 64521 Gross-Gerau, Germany
 Tel: +49 (0)61529778-0
 Fax: +49 (0)61529778-15
 Web: www.morookaeurope.com

Contact