

DIECI



AGRI PLUS GD

42.7 | 40.9



dieci.com

PERFORMANCE

Vehicle model	AGRI PLUS 42.7 VS EVO2 - GD	AGRI PLUS 40.9 VS EVO2 - GD
Maximum capacity	4200 kg (9259 lb)	4000 kg (8818 lb)
Maximum lifting height	6,9 m (22,6 ft)	8,9 m (29,2 ft)
Maximum horizontal extension	3,75 m (12,3 ft)	5,8 m (19 ft)
Fork swiveling angle	146°	146°
Pull-out force	6000 daN (13489 lbf)	6000 daN (13489 lbf)
Towing force	8200 daN (18434 lbf)	8200 daN (18434 lbf)
Maximum climb angle	60%	60%
Unladen weight	8500 kg (18739 lb)	9220 kg (20327 lb)
Max speed (referred to wheels with maximum permitted diameter)	41,7 km/h (25,9 mph)	41,7 km/h (25,9 mph)

BOOM

Vehicle model	AGRI PLUS 42.7 VS EVO2 - GD	AGRI PLUS 40.9 VS EVO2 - GD
Lifting	6,3 s	6,3 s
Descent	3,7 s	3,7 s
Extension	3,7 s	4 s
Retraction	2 s	1,7 s
Forward swiveling	2,1 s	2,1 s
Reverse swiveling	1,3 s	1,3 s

ENGINE

Vehicle model	AGRI PLUS 42.7 VS EVO2 - GD	AGRI PLUS 40.9 VS EVO2 - GD
Brand	FPT	FPT
Nominal power	103 kW (138 HP)	103 kW (138 HP)
@rpm	2200 rpm	2200 rpm
Peak power	114 kW (153 HP)	114 kW (153 HP)
@rpm	1800 rpm	1800 rpm
Operation	4-stroke	4-stroke
Injection	Electronic, Common Rail	Electronic, Common Rail
Number and arrangement of cylinders	4, Vertical in line	4, Vertical in line
Displacement	4485 cm ³ (274 in ³)	4485 cm ³ (274 in ³)
Consumption	205,9 g/kWh (338,71 lb/Hp h)	205,9 g/kWh (338,71 lb/Hp h)
@rpm	1800 rpm	1800 rpm
Emission standard	Stage IV/Tier 4f	Stage IV/Tier 4f
Exhaust gas treatment	DOC+SCR	DOC+SCR
Cooling system	Liquid	Liquid
Intake	16-valve turbo compressor, aftercooler	16-valve turbo compressor, aftercooler

DIFFERENTIAL AXLES

Vehicle model	AGRI PLUS 42.7 VS EVO2 - GD	AGRI PLUS 40.9 VS EVO2 - GD
Type of axles	2 steering, with 4 epicycloidal reduction gears	2 steering, with 4 epicycloidal reduction gears
Type of steering	4 wheels / transversal / 2 wheels	4 wheels / transversal / 2 wheels
Front axle	Rigid	Rigid
Rear axle	Swinging	Swinging
Service braking	Oil bath with servo brake on front and rear axle with double hydraulic system	Oil bath with servo brake on front and rear axle with double hydraulic system
Parking braking	Negative actuation with electronic control	Negative actuation with electronic control

HYDRAULIC SYSTEM

Vehicle model	AGRI PLUS 42.7 VS EVO2 - GD	AGRI PLUS 40.9 VS EVO2 - GD
Hydraulic pump type	No. 3 gear pumps for power-steering, movements and Fan Drive and automatic fan reversal	No. 3 gear pumps for power-steering, movements and Fan Drive with automatic fan reversal
Hydraulic pump capacity	230 L/min (60,8 gal/min)	230 L/min (60,8 gal/min)
Max. operating pressure	25,5 MPa (3698 psi)	25,5 MPa (3698 psi)
Distributor control	4in1 proportional Joystick with FNR	4in1 proportional Joystick with FNR

REFUELING

Vehicle model	AGRI PLUS 42.7 VS EVO2 - GD	AGRI PLUS 40.9 VS EVO2 - GD
Hydraulic system (total)	160,0 L (42,27 gal)	160,0 L (42,27 gal)
Fuel tank	175,0 L (46,23 gal)	175,0 L (46,23 gal)
AdBlue tank	35,0 L (9,25 gal)	35,0 L (9,25 gal)

TRANSMISSION

Vehicle model	AGRI PLUS 42.7 VS EVO2 - GD	AGRI PLUS 40.9 VS EVO2 - GD
Transmission type	Hydrostatic single speed Vario System EVO2 with electronic control	Hydrostatic single speed Vario System EVO2 with electronic control
Reversal	With electronic control operated with vehicle in motion	With electronic control operated with vehicle in motion
Inching	With electronic pedal for controlled forward movement	With electronic pedal for controlled forward movement
Drive mode	Automotive, Eco, Loader, Creeper	Automotive, Eco, Loader, Creeper

TOWING CAPACITY (upon request)

Vehicle model	AGRI PLUS 42.7 VS EVO2 - GD	AGRI PLUS 40.9 VS EVO2 - GD
Unbraked trailer	3200 kg (7055 lb)	3200 kg (7055 lb)
Inertia braking	8000 kg (17637 lb)	8000 kg (17637 lb)
Mechanical braking	6000 kg (13228 lb)	6000 kg (13228 lb)
Hydraulic/pneumatic braking	20000 kg (44092 lb)	20000 kg (44092 lb)

TIRES

Vehicle model	AGRI PLUS 42.7 VS EVO2 - GD	AGRI PLUS 40.9 VS EVO2 - GD
Standard tires	460-70R24"	460-70R24"
Optional tires	18-22.5"; 18 R22.5(445/70 R24);19.5 LR 24 (500/70 R24)	18-22.5"; 18 R22.5(445/70 R24);19.5 LR 24 (500/70 R24)

DIMENSIONS

Vehicle model	AGRI PLUS 42.7 VS EVO2 - GD	AGRI PLUS 40.9 VS EVO2 - GD
A	360 mm (14,2 in)	360 mm (14,2 in)
B	1382 mm (54,4 in)	1456 mm (57,3 in)
C	2850 mm (112,2 in)	2850 mm (112,2 in)
D	971 mm (38,2 in)	971 mm (38,2 in)
E1	2630 mm (103,5 in)	2630 mm (103,5 in)
F	4452 mm (175,3 in)	4452 mm (175,3 in)
G	5203 mm (204,8 in)	5275 mm (207,7 in)
H	2410 mm (94,9 in)	2410 mm (94,9 in)
I	960 mm (37,8 in)	960 mm (37,8 in)
K01	33°	33°
K03	9°	9°
K06	144°	144°
K07	16°	16°
K08	131°	131°
L	1870 mm (73,6 in)	1870 mm (73,6 in)
L1	5375 mm (211,6 in)	5444 mm (214,3 in)
M	2290 mm (90,2 in)	2290 mm (90,2 in)
M1	1554 mm (61,2 in)	1623 mm (63,9 in)
N1	1755 mm (69,1 in)	1755 mm (69,1 in)
O1	6403 mm (252,1 in)	6475 mm (254,9 in)
P	1099 mm (43,3 in)	1099 mm (43,3 in)
Q	3753 mm (147,8 in)	3753 mm (147,8 in)
R1	1100 mm (43,3 in)	1100 mm (43,3 in)
S1	120 mm (4,7 in)	120 mm (4,7 in)
T1	4887 mm (192,4 in)	4951 mm (194,9 in)
U1	3787 mm (149,1 in)	3851 mm (151,6 in)
V1	8892 mm (350,1 in)	9034 mm (355,7 in)
P1	50 mm (2 in)	50 mm (2 in)
Q1	1200 mm (47,2 in)	1200 mm (47,2 in)

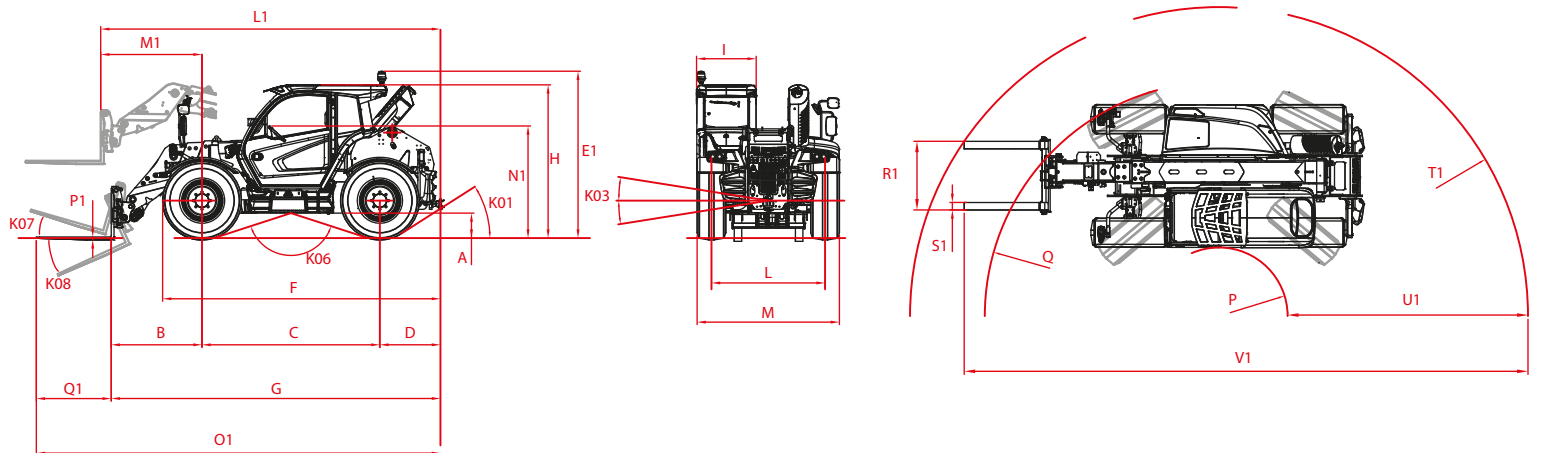

MAX
4200 kg / 9259 lb

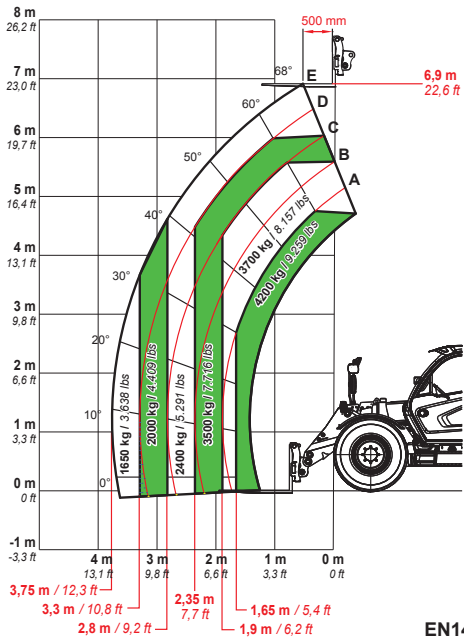

DOC10000838



42.7

EN1459 Annex-B

MAX
4000 kg / 8818 lb

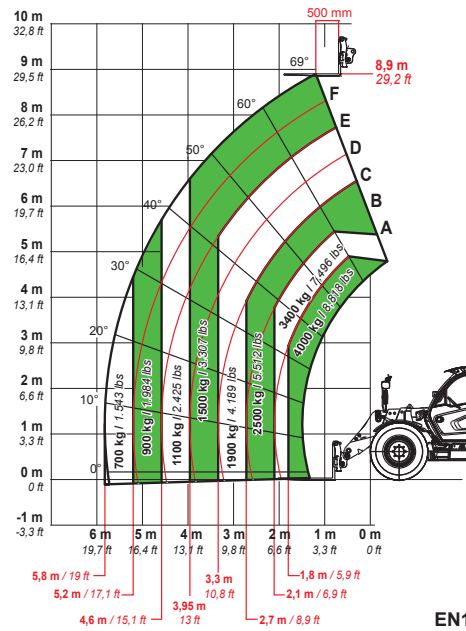

DOC10000839



40.9

EN1459 Annex-B