

DIECI



HERCULES

100.10 | 120.10 | 190.10 | 210.10 | 230.10



dieci.com

PERFORMANCE

Vehicle model	HERCULES 100.10	HERCULES 120.10	HERCULES 190.10	HERCULES 210.10	HERCULES 230.10
Maximum capacity	10000 kg (22046 lb)	12000 kg (26455 lb)	19000 kg (41888 lb)	21000 kg (46297 lb)	23000 kg (50706 lb)
Maximum lifting height	9,50 m (31,2 ft)	9,50 m (31,2 ft)	10,20 m (33,5 ft)	10,20 m (33,5 ft)	10,15 m (33,3 ft)
Maximum horizontal extension	5,15 m (16,9 ft)	5,1 m (16,7 ft)	5,15 m (16,9 ft)	5,15 m (16,9 ft)	5,11 m (16,8 ft)
Fork swiveling angle	144°	144°	120°	120°	113°
Pull-out force	9700 daN (21806 lbf)	9700 daN (21806 lbf)	16200 daN (36419 lbf)	18900 daN (42489 lbf)	18900 daN (42489 lbf)
Towing force	11000 daN (24729 lbf)	11000 daN (24729 lbf)	19500 daN (43838 lbf)	19500 daN (43838 lbf)	19500 daN (43838 lbf)
Maximum climb angle	36%	36%	36,5%	36,5%	35%
Unladen weight	16000 kg (35274 lb)	16800 kg (37038 lb)	24500 kg (54013 lb)	27500 kg (60627 lb)	29450 kg (64926 lb)
Max speed (referred to wheels with maximum permitted diameter)	35 km/h (21,7 mph)	35 km/h (21,7 mph)	23 km/h (14,3 mph)	23 km/h (14,3 mph)	22 km/h (13,7 mph)

BOOM

Vehicle model	HERCULES 100.10	HERCULES 120.10	HERCULES 190.10	HERCULES 210.10	HERCULES 230.10
Lifting	16,5 s	19,0 s	20,0 s	25,2 s	28,6 s
Descent	13,2 s	15,2 s	20,5 s	23,5 s	24,1 s
Extension	13,2 s	13,2 s	20,1 s	20,1 s	20,1 s
Retraction	8,3 s	8,3 s	9,8 s	9,8 s	9,8 s
Forward swiveling	5,3 s	5,3 s	5,6 s	8,1 s	15,3 s
Reverse swiveling	4,0 s	4,0 s	4,3 s	5,3 s	10,5 s

ENGINE (Stage 3B / Tier 4i)

Vehicle model	HERCULES 100.10	HERCULES 120.10	HERCULES 190.10	HERCULES 210.10	HERCULES 230.10
Brand	FPT	FPT	FPT	FPT	FPT
Nominal power	125 kW (168 HP)	125 kW (168 HP)	125 kW (168 HP)	125 kW (168 HP)	125 kW (168 HP)
@rpm	2200 rpm	2200 rpm	2200 rpm	2200 rpm	2200 rpm
Peak power	129 kW (173 HP)	129 kW (173 HP)	129 kW (173 HP)	129 kW (173 HP)	129 kW (173 HP)
@rpm	1900 rpm	1900 rpm	1900 rpm	1900 rpm	1900 rpm
Operation	4-stroke	4-stroke	4-stroke	4-stroke	4-stroke
Injection	Electronic, Common Rail	Electronic, Common Rail	Electronic, Common Rail	Electronic, Common Rail	Electronic, Common Rail
Number and arrangement of cylinders	4, Vertical in line	4, Vertical in line	4, Vertical in line	4, Vertical in line	4, Vertical in line
Displacement	4485 cm ³ (274 in ³)	4485 cm ³ (274 in ³)	4485 cm ³ (274 in ³)	4485 cm ³ (274 in ³)	4485 cm ³ (274 in ³)
Consumption	208 g/kWh (342,16 lb/Hp h)	208 g/kWh (342,16 lb/Hp h)	208 g/kWh (342,16 lb/Hp h)	208 g/kWh (342,16 lb/Hp h)	208 g/kWh (342,16 lb/Hp h)
@rpm	1900 rpm	1900 rpm	1900 rpm	1900 rpm	1900 rpm
Emission standard	Stage IIIB/Tier 4i	Stage IIIB/Tier 4i	Stage IIIB/Tier 4i	Stage IIIB/Tier 4i	Stage IIIB/Tier 4i
Exhaust gas treatment	SCR (AdBlue)	SCR (AdBlue)	SCR (AdBlue)	SCR (AdBlue)	SCR (AdBlue)
Cooling system	Liquid	Liquid	Liquid	Liquid	Liquid
Intake	16-valve turbo compressor+ aftercooler, air pre-filter, fuel pre-filter	16-valve turbo compressor+ aftercooler, air pre-filter, fuel pre-filter	Turbo compressor 16 valve	Turbo compressor 16 valve	Turbo compressor 16 valve

DIFFERENTIAL AXLES

Vehicle model	HERCULES 100.10	HERCULES 120.10	HERCULES 190.10	HERCULES 210.10	HERCULES 230.10
Type of axles	2 steering, with 4 planetary reduction gears	2 steering, with 4 planetary reduction gears	2 steering, with 4 planetary reduction gears	2 steering, with 4 planetary reduction gears	2 steering, with 4 epicycloidal reduction gears
Type of steering	4 wheels / transversal / 2 wheels	4 wheels / transversal / 2 wheels	4 wheels / transversal / 2 wheels	4 wheels / transversal / 2 wheels	4 wheels / transversal / 2 wheels
Front axle	With transverse leveling (8° + 8°) with control in the cab and 45% self-locking differential	With transverse leveling (8° + 8°) with control in the cab and 45% self-locking differential	With transverse leveling (8° + 8°) with control in the cab	With transverse leveling (8° + 8°) with control in the cab	With transverse leveling (6° + 6°) with control in the cab
Rear axle	Swinging	Swinging	Swinging	Swinging	Swinging
Service braking	Oil bath with servo brake on front and rear axle with double hydraulic system	Oil bath with servo brake on front and rear axle with double hydraulic system	Oil bath with servo brake on front and rear axle with double hydraulic system	Oil bath with servo brake on front and rear axle with double hydraulic system	Oil bath with servo brake on front and rear axle with double hydraulic system
Parking braking	Negative actuation with electrical control	Negative actuation with electrical control	Negative actuation with electrical control	Negative actuation with electrical control	Negative actuation with electrical control
Differential	-	-	100% lockable	100% lockable	100% lockable

HYDRAULIC SYSTEM

Vehicle model	HERCULES 100.10	HERCULES 120.10	HERCULES 190.10	HERCULES 210.10	HERCULES 230.10
Hydraulic pump type	"Load Sensing" variable flow pump for boom movements. Gear pump for power steering drive and for the cooling fan	"Load Sensing" variable flow pump for boom movements. Gear pump for power steering drive and for the cooling fan	"Load Sensing" variable flow pump for boom movements. And power steering. Gear pump for cooling fan operation	"Load Sensing" variable flow pump for boom movements. And power steering. Gear pump for cooling fan operation	"Load Sensing" variable flow pump for boom movements. And power steering. Gear pump for cooling fan operation
Hydraulic pump capacity	160 L/min (42,3 gal/min)	160 L/min (42,3 gal/min)	170 L/min (44,9 gal/min)	170 L/min (44,9 gal/min)	170 L/min (44,9 gal/min)
Max. operating pressure	30,0 MPa (4351 psi)	30,0 MPa (4351 psi)	35,0 MPa (5076 psi)	35,0 MPa (5076 psi)	35,0 MPa (5076 psi)
Distributor control	4in1 proportional Joystick	4in1 proportional Joystick	4in1 proportional Joystick	4in1 proportional Joystick	4 in1 proportional Joystick

REFUELING

Vehicle model	HERCULES 100.10	HERCULES 120.10	HERCULES 190.10	HERCULES 210.10	HERCULES 230.10
Hydraulic system (total)	246,0 L (64,99 gal)	246,0 L (64,99 gal)	246,0 L (64,99 gal)	246,0 L (64,99 gal)	246,0 L (64,99 gal)
Fuel tank	207,0 L (54,68 gal)	207,0 L (54,68 gal)	207,0 L (54,68 gal)	207,0 L (54,68 gal)	207,0 L (54,68 gal)
AdBlue tank	30,0 L (7,93 gal)	30,0 L (7,93 gal)	30,0 L (7,93 gal)	30,0 L (7,93 gal)	30,0 L (7,93 gal)

TRANSMISSION

Vehicle model	HERCULES 100.10	HERCULES 120.10	HERCULES 190.10	HERCULES 210.10	HERCULES 230.10
Transmission type	Hydrostatic with variable flow pump	Hydrostatic with variable flow pump	Hydrostatic with variable flow pump	Hydrostatic with variable flow pump	Hydrostatic with variable displacement pump
Hydraulic motor	Hydrostatic with continuous automatic adjustment	Hydrostatic with continuous automatic adjustment	Hydrostatic with continuous automatic adjustment	Hydrostatic with continuous automatic adjustment	Hydrostatic with continuous automatic adjustment
Reversal	Electro-Hydraulic	Electro-Hydraulic	Electro-Hydraulic	Electro-Hydraulic	Electro-Hydraulic
Inching	With hydraulic pedal for controlled forward movement	With hydraulic pedal for controlled forward movement	With hydraulic pedal for controlled forward movement	With hydraulic pedal for controlled forward movement	With hydraulic pedal for controlled forward movement
Transmission gearbox	Servocontrolled 2-speed	Servocontrolled 2-speed	Servocontrolled 2-speed	Servocontrolled 2-speed	Servo-controlled 2-speed
Differential	-	-	100% lockable	100% lockable	100% lockable

TIRES

Vehicle model	HERCULES 100.10	HERCULES 120.10	HERCULES 190.10	HERCULES 210.10	HERCULES 230.10
Standard tires	17.5x25"	17.5x25"	20.5R25"	23.5R25"	26,5R25"
Optional tires	17.5R25"	17.5R25"	23.5R25"	-	-

DIMENSIONS

Vehicle model	HERCULES 100.10	HERCULES 120.10	HERCULES 190.10	HERCULES 210.10	HERCULES 230.10
A	490 mm (19,3 in)	490 mm (19,3 in)	530 mm (20,9 in)	530 mm (20,9 in)	470 mm (18,5 in)
B	1270 mm (50 in)	1270 mm (50 in)	1320 mm (52 in)	1320 mm (52 in)	1320 mm (52 in)
C	3300 mm (129,9 in)	3300 mm (129,9 in)	3850 mm (151,6 in)	3850 mm (151,6 in)	3850 mm (151,6 in)
D	1480 mm (58,3 in)	1480 mm (58,3 in)	1630 mm (64,2 in)	1630 mm (64,2 in)	1630 mm (64,2 in)
G	6050 mm (238,2 in)	6050 mm (238,2 in)	6800 mm (267,7 in)	6800 mm (267,7 in)	6800 mm (267,7 in)
H	2890 mm (113,8 in)	2890 mm (113,8 in)	2930 mm (115,4 in)	2930 mm (115,4 in)	2980 mm (117,3 in)
I	980 mm (38,6 in)	980 mm (38,6 in)	980 mm (38,6 in)	980 mm (38,6 in)	980 mm (38,6 in)
L	1975 mm (77,8 in)	1975 mm (77,8 in)	2015 mm (79,3 in)	2045 mm (80,5 in)	2180 mm (85,8 in)
M	2420 mm (95,3 in)	2420 mm (95,3 in)	2600 mm (102,4 in)	2700 mm (106,3 in)	2880 mm (113,4 in)
P	1480 mm (58,3 in)	1480 mm (58,3 in)	3530 mm (139 in)	3530 mm (139 in)	3530 mm (139 in)
Q	4350 mm (171,3 in)	4350 mm (171,3 in)	6500 mm (255,9 in)	6500 mm (255,9 in)	6530 mm (257,1 in)
R	4580 mm (180,3 in)	4580 mm (180,3 in)	6500 mm (255,9 in)	6500 mm (255,9 in)	6750 mm (265,7 in)
T	134 mm (5,3 in)	134 mm (5,3 in)	181 mm (7,1 in)	181 mm (7,1 in)	181 mm (7,1 in)

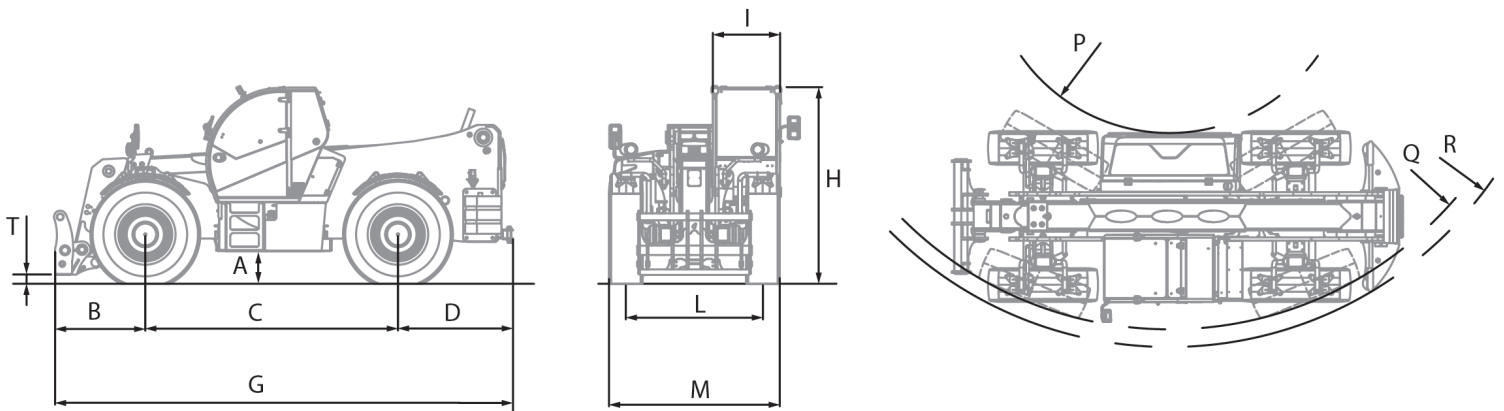

MAX 10,0 t

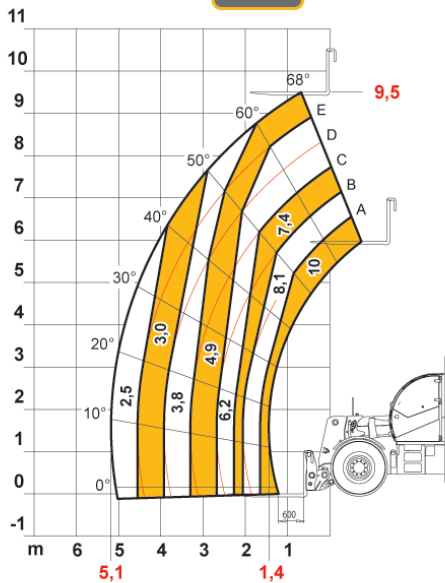

AXBI537



EN1459

100.10

MAX 12,0 t

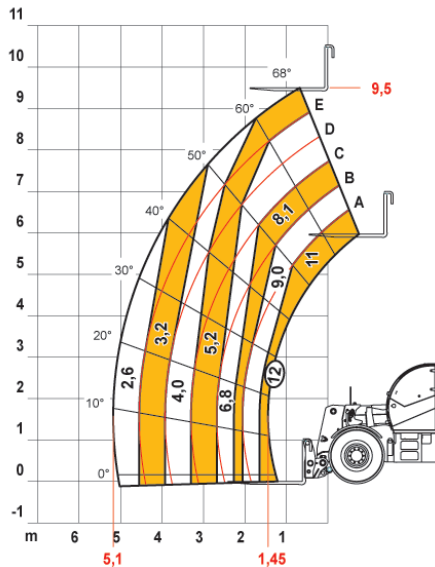

DOCDI0000487



EN1459

120.10

MAX 19,0 t

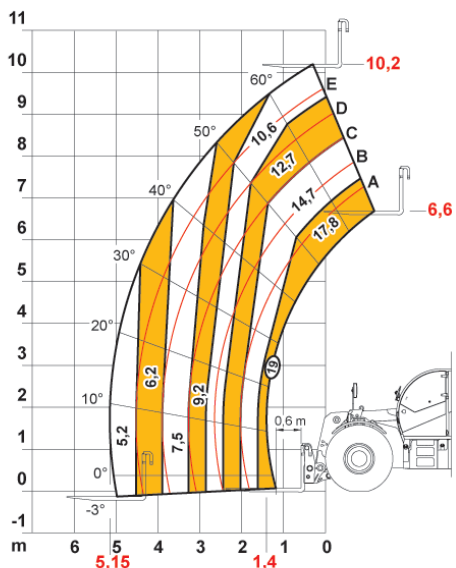

DOCDI0000197



EN1459

190.10

MAX 21,0 t

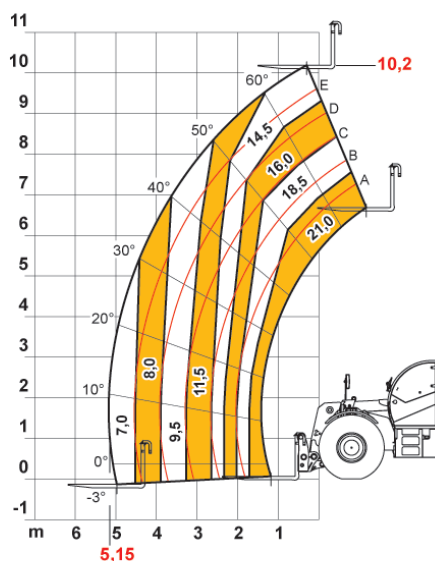

AXBI452



EN1459

210.10

MAX 23000 kg / 50706 lb

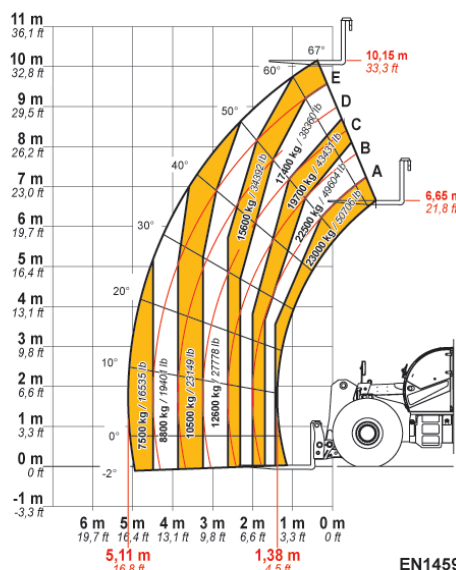

DOCDI0000810



EN1459 Annex-B

230.10