

KOMATSU

WA600-8

EU Stage IV Engine

WHEEL LOADER



WA600

ENGINE POWER

396 kW / 530 HP @ 1.800 rpm

OPERATING WEIGHT

54.170 - 56.740 kg

BUCKET CAPACITY

6,4 - 7,8 m³

Walk-Around

**ENGINE POWER**

396 kW / 530 HP @ 1.800 rpm

OPERATING WEIGHT

54.170 - 56.740 kg

BUCKET CAPACITY

6,4 - 7,8 m³

W/A600-8



INCREASED FUEL EFFICIENCY AND ENVIRONMENTAL PERFORMANCE

Powerful and Environmentally Friendly

- EU Stage IV engine
- Komatsu SmartLoader Logic
- Large-capacity torque converter with standard lock-up
- Adjustable auto idle shutdown

Maximised Efficiency

- High efficiency buckets
- Superior dumping height and reach
- Wide tread and long wheelbase

First-Class Comfort

- New, air-suspended, heated and ventilated operator seat with integrated EPC lever console
- Large multifunctional monitor
- Rear-view camera system

State-of-the-Art Controls

- Automatic digging system
- Electronic Pilot Control (EPC) standard
- Intelligent gas pedal

Easy Maintenance

- Swing-out reversible fan
- Wide core, modular radiator
- Side opening, double swing engine doors

KOMTRAX™ Plus

- Komatsu Wireless Monitoring System
- Increased operational data and fuel savings



A maintenance program
for Komatsu customers

Powerful and Environmentally Friendly



Komatsu fuel-saving technology

Fuel consumption on the WA600-8 is now up to 13% lower, thanks to the new Komatsu EU Stage IV engine with optimised engine power control, a highly efficient power train and a load sensing hydraulic system with variable displacement piston pumps that minimises loss.

Large-capacity torque converter with standard lock-up

With its large-capacity torque converter, the completely redesigned Komatsu drive train offers optimum efficiency and an unparalleled rimpull-to-weight ratio. By delivering high rimpull at low speeds, it makes child's play of heavy jobs like penetration of dense material. This means higher productivity in V-Shape loading, even in confined spaces.

Komatsu SmartLoader Logic

The WA600-8 features Komatsu SmartLoader Logic, a fully automatic engine control system. Without interfering with normal operations, this technology acquires data from various sensors in the vehicle and delivers optimal engine torque for each work phase. It limits torque during less demanding operations and reduces fuel usage without decreasing production.

WA600-8

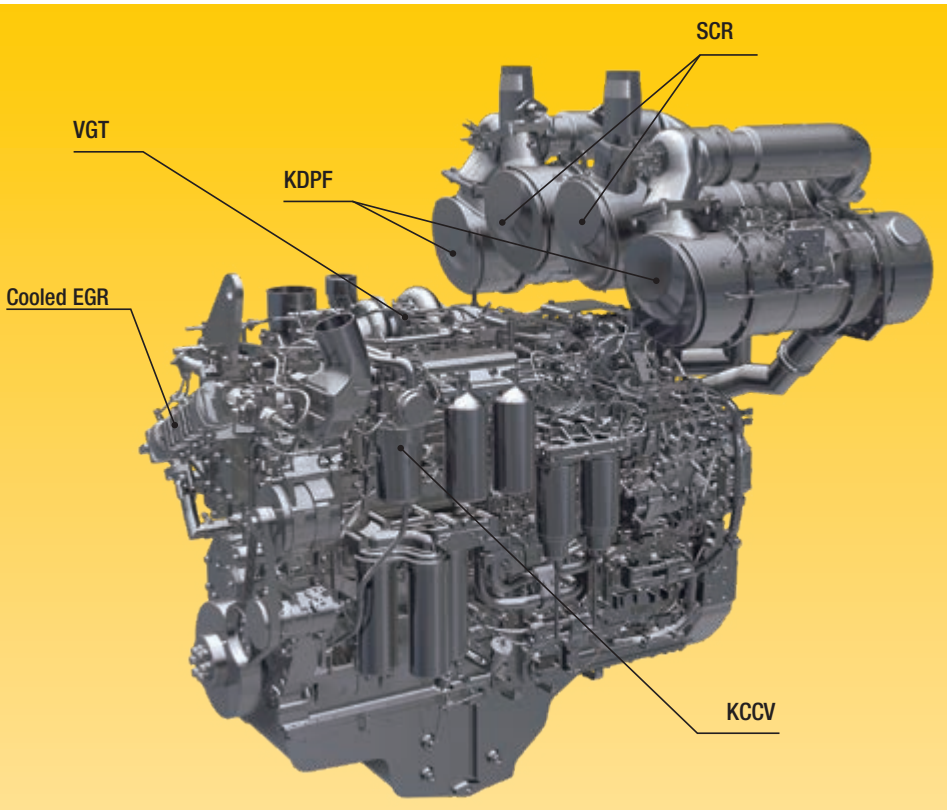

Komatsu EU Stage IV

The Komatsu EU Stage IV engine is productive, dependable and efficient. With ultra-low emissions, it provides a lower environmental impact and a superior performance to help reduce operating costs and lets the operator work in complete peace of mind.

Heavy-duty aftertreatment

The aftertreatment system combines a Komatsu Diesel Particulate Filter (KDPF) and Selective Catalytic Reduction (SCR). The SCR injects the correct amount of AdBlue® into the system at the proper rate to break down NOx into water (H₂O) and non-toxic nitrogen gas (N₂). NOx emissions are reduced by 80% vs. EU Stage IIIB engines.

Exhaust Gas Recirculation (EGR)

Cooled EGR is a technology well-proven in current Komatsu engines. The increased capacity of the EGR cooler now ensures very low NOx emissions and a better engine performance.

Komatsu Closed Crankcase Ventilation (KCCV)

Crankcase emissions (blow-by gas) are passed through a CCV filter. The oil mist trapped in the filter is returned back to the crankcase while the filtered gas is returned to the air intake.

High-Pressure Common Rail (HPCR)

To achieve complete fuel burn and lower exhaust emissions, the heavy-duty High-Pressure Common Rail fuel injection system is computer controlled to deliver a precise quantity of pressurised fuel into the redesigned engine combustion chamber by multiple injections.

Variable Geometry Turbo (VGT)

The VGT provides optimal airflow to the engine combustion chamber under all speed and load conditions. Exhaust gas is cleaner, fuel economy is improved while machine power and performance are maintained.

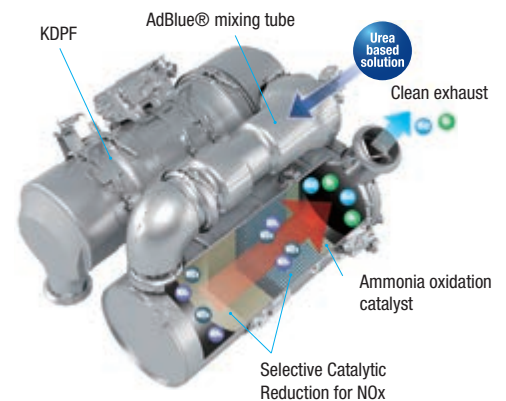

Eco-gauge and an Eco guidance with active recommendations help maximising fuel savings



Adjustable auto idle shutdown automatically turns off the engine after it idles for a set period of time

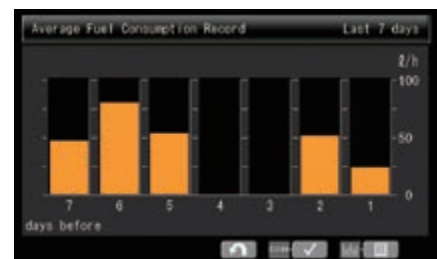

Fuel consumption history

Maximised Efficiency

Faster Load & Carry

The sequential torque converter lock-up system delivers unbeatable productivity and fuel efficiency in Load & Carry and short distance transport applications. The operator can engage the system from 2nd to 4th gear. It noticeably increases travel speed, particularly when going uphill, thanks to the larger tractive force. It also significantly reduces fuel consumption by eliminating converter losses.

Superior dumping height and reach

The long lifting frame allows an enormous dumping height of 3.915 m and a reach of 1.885 m that is just as impressive (with a 7,0 m³ bucket, measured to the cutting edge). With this working range, loading high feeders or trucks becomes easy and fast.



New high efficiency buckets

Soil slips easily from the redesigned bucket, and digging work is more efficient. Operations are easier and productivity improved, especially in combination with the new auto digging system.

Precision control

Komatsu's CLSS hydraulics enables extremely precise control of the work equipment, and ensures that the bucket, boom and hydraulically driven attachments can all move smoothly at the same time. The WA600-8 also features variable-displacement pumps on both the hydraulic and steering systems. These pumps deliver the exact amount of oil required, dramatically improving fuel efficiency.



New automatic digging system

The new automatic digging system actuates the bucket tilt and lifting operations by detecting the sensing pressure applied to the work equipment. This system greatly reduces operator's fatigue and ensures an ideal loading capacity.



WA600-8



First-Class Comfort

Increased comfort

In the wide Komatsu SpaceCab™, a standard air-suspended high-back seat, heated and ventilated for improved comfort and with fully adjustable armrests, is the centre of a comfortable and low-fatigue working environment. High visibility and ergonomic controls further assist to maximise the operator's productivity.

Perfect operator convenience

In addition to the standard radio, the WA600-8 has an auxiliary input for connecting external devices and play music through the cab speakers. Two 12-volt power ports are also incorporated in the cab. Proportional controls are fitted as standard for safe and precise operation of attachments.

Advanced monitoring system

The WA600-8 has a machine monitoring system that manages all essential functions. Specific settings can be saved in the attachment management program to speed up work in applications requiring a frequent change of buckets or other attachments.



WA600-8

State-of-the-Art Controls

New, fully air suspended operator station

The wide spacious cab features a new, fully air suspended operator seat that includes the side consoles mounted together with a standard high back fully adjustable seat, heated and ventilated for improved comfort.

“By Wire” operating

The Electronic Pilot Control (EPC) lever console is integrated with the seat and can be easily adjusted to suit any operator. The short levers are fingertip controlled for precise and fatigue-free operating, with a no-vibration modulating function for slowing and stopping a lowering bucket. The upper and lower boom cut-out position can be pre-set with a switch.

Auto-kickdown

The WA600-8 can automatically shift down from F2 to F1 to make operations easier and more productive.

Intelligent gas pedal

To reduce fuel usage, Komatsu's innovative thrust-sensing gas pedal automatically helps you match the timing of gear shifts to the load.

In heavy-duty work, requiring high rimpull and maximum acceleration, we tend to press heavily on the gas pedal. The WA600-8 anticipates this and shifts up gears as late as possible. In light-duty work, where fuel consumption is a major factor, the operator will intuitively press the gas pedal lightly. Again, the machine anticipates this – and shifts up gears as early as possible to achieve highest fuel efficiency.

Variable traction control system

In limited traction situations, such as on sandy or muddy grounds, the operator can reduce slippage by activating the variable traction control system. Optimum rim pull is adjusted with a control knob from 100% to 20%.

Rear view camera

A standard fitment camera gives an exceptionally clear view of the rear work zone on the wide-screen colour monitor panel. The low profile camera is adjustable and integrated into the engine hood's shape.

Advanced joystick steering system

The advanced “feedback” steering system allows both steering and directional selection to be controlled by wrist and finger. With the feedback function, the machine steering angle is exactly the same angle as the lever tilt angle. A steering wheel is also available as an alternative.

Engine RPM set system with auto deceleration

Low idle RPM can be preset easily with a push button. The system provides auto deceleration for reduced fuel consumption.



Auxiliary input (MP3 jack) and two 12-volt power ports



Hot and cool box



Advanced joystick steering system

Information & Communication Technology



Lower operating costs

Komatsu ICT contributes to the reduction of operating costs by assisting to comfortably and efficiently manage operations. It raises the level of customer satisfaction and the competitive edge of our products.

Large TFT colour monitor

A large user-friendly colour monitor enables safe, accurate and smooth work. Multilingual and with all essential information available at a glance, it features simple and easy-to-operate switches and multifunction keys that provide fingertip access to a wide range of functions and operating information.

Eco guidance

The monitor panel displays instant guidance messages to help promote energy saving, and the Eco-gauge indicates the actual fuel consumption: keep the Eco-gauge in the green zone for better fuel efficiency. To further improve savings, logs can be consulted for operations, Eco guidance and fuel consumption.



Information at a glance: basic dashboard LCD monitor



A multifunction monitor displays and controls a wealth of operational and maintenance information

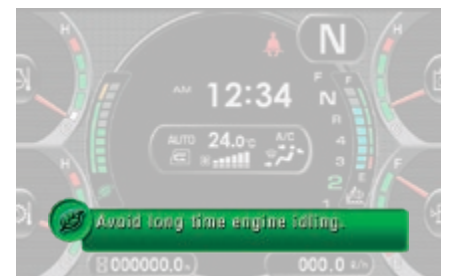

Eco guidance supports energy saving in real time

W/A 600-8

KOMTRAX™

What

- KOMTRAX™ is Komatsu's remote equipment monitoring and management system
- KOMTRAX™ continuously monitors and records machine health and operational data
- Information such as fuel consumption, utilization, and a detailed history aids in making repair or replacement decisions

Who

- KOMTRAX™ is standard equipment on all Komatsu construction products

When

- Know when your machines are running or idling and make decisions that will improve your fleet utilization
- Detailed movement records ensure you know when and where your equipment is moved
- Up to date records allow you to know when maintenance was done and help you plan for future maintenance needs

Where

- KOMTRAX™ data can be accessed virtually anywhere through your computer, the web or your smart phone
- Automatic alerts keep fleet managers up to date on the latest machine notifications

Why

- Knowledge is power - make informed decisions to manage your fleet better
- Knowing your idle time and fuel consumption will help maximize your machine efficiency
- Take control of your equipment - any time, anywhere



KOMTRAX Plus

Equipment management support

KOMTRAX™ Plus enables expanded monitoring of the fleet via satellite and wireless LAN. Users can analyze "machine health" and performance from a remote location, on a near-real time basis. This includes component condition and trend data. By making this critical information readily accessible, KOMTRAX™ Plus is an effective tool in maximizing productivity and lowering operating cost.

Easy Maintenance



Easy access to service points

Large double swing doors give a convenient access to all daily service points. With long service intervals and filters collected in a centralised arrangement, machine downtime is reduced to a minimum.

Diesel particulate filter regeneration

No interruption or extension of daily work is required to regenerate the diesel particle filter system. Due to its superior Komatsu technology, KDPF regeneration takes place automatically, at any time.

AdBlue® tank

The AdBlue® tank is located on the right hand side of the machine behind a ladder for easy access.



Modular design wide core radiator with reversible fan

The wide core modular radiator prevents clogging even in a dusty work environment. To minimize manual cleaning, a reversible fan blows the dust out. The radiator core can be removed without the entire assembly, keeping repair costs down.

Equipment Management and Monitoring System (EMMS)

The large high resolution monitor panel displays various machine information and allows for multiple settings. The "Operation Records" menu shows records of the average fuel consumption, idling hours, and other features. Abnormality codes are clearly displayed and stored to alert you and simplify troubleshooting. The monitor also provides for advanced monitoring of the system parameters through the Service Mode to aid in troubleshooting and reduce downtime.



Basic maintenance screen



Aftertreatment device regeneration screen for the KDPF



AdBlue® level gauge and refill guidance

Komatsu CARE™

Komatsu CARE™ is a maintenance program that comes as standard with



your new Komatsu machine. It covers factory-scheduled maintenance, performed with Komatsu Genuine parts by Komatsu-trained technicians. Depending on your machine's engine, it also offers extended coverage of the Komatsu Diesel Particulate Filter (KDPF) or the Komatsu Diesel Oxidation Catalyst (KDOC), and of the Selective Catalytic Reduction (SCR). Please contact your local Komatsu distributor for terms and conditions.

WA600-8

Quality You Can Rely On

Designed and built by Komatsu

The engine, hydraulics, power train, front and rear axles are original Komatsu components. All these components are subject to the highest quality standards right down to the smallest screw.

Heavy-duty axles

The heavy-duty axles allow exceptional service life even under the toughest working conditions. The optional limited slip differentials are most suitable for soft and slippery ground like sand or wet soil.

Robust torsion-resistant main frame

The frame design with hinge points far apart guarantees the high stability for the overall construction and reduces bearing stress in the torsional ranges.

Wet multi-disc service brake

The multi-disc service brake is encapsulated and runs in an oil bath. The brake stays clean and operates at low temperature for increased service intervals and a long lifetime. The braking system uses two independent hydraulic circuits, for added reliability.



Robust torsion-resistant main frame

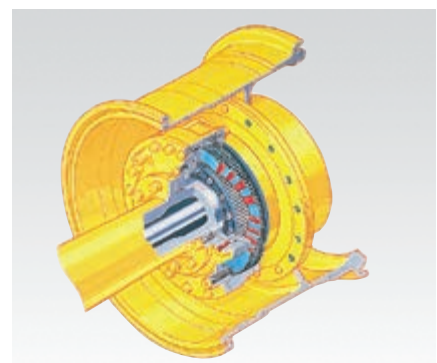

Wet multi-disc service brake

Specifications

ENGINE

Model	Komatsu SAA6D170E-7
Type	Common rail direct injection, water-cooled, emissionised, turbocharged, after-cooled diesel
Engine power	
at rated engine speed	1.800 rpm
ISO 14396	396 kW/530 HP
ISO 9249 (net engine power)	395 kW/529 HP
No. of cylinders	6
Bore × stroke	170 × 170 mm
Displacement	23,15 l
Fan drive type	Hydraulic
Alternator	140 A/24 V
Starter motor	2 × 11 kW/24 V
Filter	Full-flow type
Air-filter type	Dry-air filter with automatic dust emission and preliminary purification including a dust display
Fuel	Diesel fuel, conforming to EN590 Class 2/ Grade D. Paraffinic fuel capability (HVO, GTL, BTL), conforming to EN 15940:2016

TRANSMISSION

Type	Automatic powershift transmission
Torque converter	3-element, 1-stage, 2-phase, with lock-up clutch

SPEEDS IN KM/H (WITH 35/65-33 TYRES)

Gear	1.	2.	3.	4.
Forward (with lock-up)	6,7	11,7 (12,4)	20,3 (21,7)	33,8 (37,7)
Reverse (with lock-up)	7,3	12,8 (13,5)	22,0 (23,7)	37,0 (41,0)

CHASSIS AND TYRES

System	4-wheel drive
Front axle	Fixed, full-floating
Rear axle	Center-pin support, full-floating, 22° total oscillation
Reduction gear	Spiral bevel gear
Differential gear	Conventional type
Final drive	Planetary gear in an oil bath
Tyres	35/65-33

BRAKES

Operating brakes	Hydraulically actuated, wet multi-disc brakes on all wheels
Parking brake	Wet multi-disc
Emergency brake	Uses the parking brake

STEERING SYSTEM

System	Articulated frame steering
Steering angle to either side	43°
Steering pump	Variable piston pump
Working pressure	350 kg/cm ²
Pumping capacity	163 l/min
No. of steering cylinders	2
Type	Double-action
Bore diameter × stroke	115 × 510 mm
Smallest turn (outer edge of the tyre)	7.075 mm

HYDRAULIC SYSTEM

Type	Komatsu CLSS (Closed Centre Load Sensing System)
Hydraulic pump	Variable piston pump
Working pressure	350 kg/cm ²
Maximum pump flow	239 + 239 l/min
No. of hydraulic/bucket cylinders	2/1
Type	Double-action
Bore diameter × stroke	
Boom cylinder	200 × 1.067 mm
Bucket cylinder	225 × 776 mm
Hydraulic cycle with rated load bucket filling	
Raise time	8,7 s
Lowering time (empty)	4,1 s
Dumping time	2,3 s

SERVICE REFILL CAPACITIES

Fuel tank	718 l
Engine oil	86 l
Hydraulic system	443 l
Cooling system	150 l
Front axle	185 l
Rear axle	195 l
Torque converter and transmission	78 l
AdBlue® tank	39,7 l

ENVIRONMENT

Engine emissions	Fully complies with EU Stage IV exhaust emission regulations
Noise levels	
LwA external	111 dB(A) (2000/14/EC Stage II)
LpA operator ear	73 dB(A) (ISO 6396 dynamic test)
Vibration levels (EN 12096:1997)	
Hand/arm	≤ 2,5 m/s ² (uncertainty K = 0,27 m/s ²)
Body	≤ 0,5 m/s ² (uncertainty K = 0,28 m/s ²)
Contains fluorinated greenhouse gas HFC-134a (GWP 1430). Quantity of gas 0,9 kg, CO ₂ equivalent 1,29 t.	

BUCKET SELECTION GUIDE

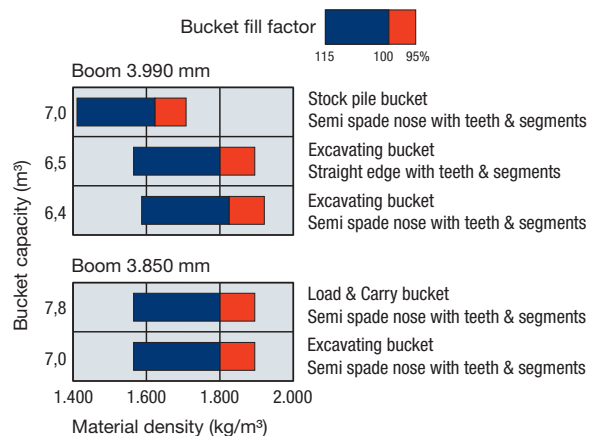

Dimensions & Performance Figures

MEASUREMENTS AND WORKING SPECIFICATIONS

	Boom 3.990 mm	Boom 3.850 mm
Tread	2.650 mm	2.650 mm
Width over tyres	3.590 mm	3.590 mm
A Wheel base	4.500 mm	4.500 mm
B Hinge pin height	5.885 mm	5.665 mm
C Hinge pin height, carry position	720 mm	670 mm
D Ground clearance	525 mm	525 mm
E Hitch height	1.320 mm	1.320 mm
F Overall height, top of the stack	4.375 mm	4.375 mm
G Overall height, cab	4.500 mm	4.500 mm

Dimensions with 35/65-33-36PR (L-4) tyres

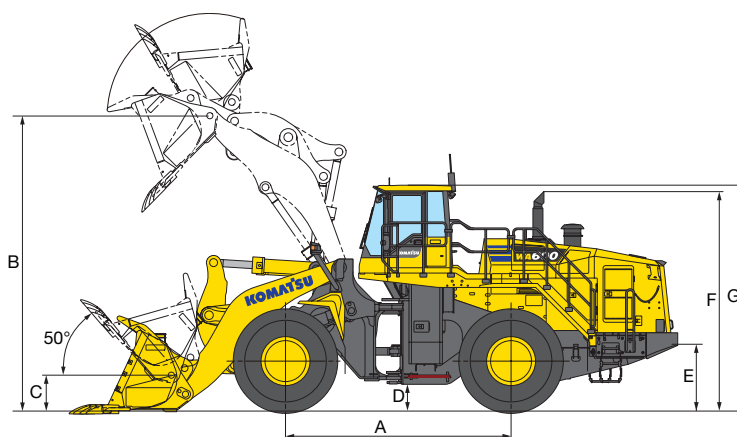

	Boom 3.990 mm					Boom 3.850 mm				
	Excavating bucket			Stock pile bucket	Heavy-duty bucket	Excavating bucket			Load & Carry bucket	
	Spade nose teeth and BSE ^{1) 2)}	Straight edge teeth and BSE ²⁾	Straight edge B.O.C. ³⁾	Spade nose teeth and BSE ^{1) 2)}	Spade nose teeth and BSE ²⁾	Spade nose teeth and BSE ^{1) 2)}	Straight edge teeth and BSE ²⁾	Straight edge B.O.C. ³⁾	Spade nose teeth and BSE ^{1) 2)}	
Bucket capacity	heaped	6,4 m ³	6,5 m ³	6,5 m ³	7,0 m ³	6,4 m ³	7,0 m ³	7,0 m ³	7,0 m ³	7,8 m ³
	struck	5,3 m ³	5,4 m ³	5,4 m ³	5,8 m ³	5,3 m ³	5,8 m ³	5,8 m ³	5,8 m ³	6,6 m ³
Bucket width	3.805 mm	3.685 mm	3.685 mm	3.805 mm	3.806 mm	3.805 mm	3.685 mm	3.685 mm	3.805 mm	
Bucket weight	5.434 kg	5.020 kg	4.745 kg	5.594 kg	5.405 kg	5.594 kg	4.865 kg	4.875 kg	5.791 kg	
Dumping clearance, max. height and 45° dump angle ³⁾	3.965 mm	4.180 mm	4.365 mm	3.915 mm	3.930 mm	3.700 mm	3.905 mm	4.105 mm	3.615 mm	
Reach at max. height and 45° dump angle ³⁾	1.835 mm	1.610 mm	1.460 mm	1.885 mm	1.820 mm	1.915 mm	1.690 mm	1.550 mm	2.000 mm	
Reach at 2.130 mm clearance and 45° dump angle	3.030 mm	2.875 mm	2.765 mm	3.065 mm	3.000 mm	2.920 mm	2.775 mm	2.670 mm	2.970 mm	
Reach with arm horizontal and bucket level	4.175 mm	3.870 mm	3.630 mm	4.245 mm	4.185 mm	4.105 mm	3.800 mm	3.560 mm	4.225 mm	
Operating height (fully raised)	7.925 mm	7.925 mm	7.925 mm	8.040 mm	7.925 mm	7.280 mm	7.775 mm	7.775 mm	7.885 mm	
Overall length	12.145 mm	11.840 mm	11.600 mm	12.215 mm	12.550 mm	12.030 mm	11.725 mm	11.485 mm	12.050 mm	
Loader clearance circle diameter (bucket at carry, outside corner of bucket)	17.050 mm	17.060 mm	16.900 mm	17.090 mm	17.050 mm	16.770 mm	16.920 mm	16.765 mm	16.990 mm	
Digging depth:	0°	130 mm	135 mm	105 mm	130 mm	170 mm	130 mm	140 mm	100 mm	130 mm
	10°	530 mm	480 mm	410 mm	540 mm	565 mm	540 mm	495 mm	410 mm	560 mm
Static tipping load:	straight	38.790 kg	38.225 kg	39.510 kg	38.620 kg	38.825 kg	38.400 kg	39.140 kg	39.130 kg	42.150 kg
	43° full turn	33.160 kg	33.530 kg	33.775 kg	33.020 kg	33.190 kg	33.250 kg	33.850 kg	33.840 kg	36.300 kg
Breakout force		387 kN	448 kN	447 kN	375 kN	387 kN	378 kN	433 kN	432 kN	355 kN
		39.500 kg	45.685 kg	45.580 kg	38.200 kg	39.500 kg	38.600 kg	44.150 kg	44.050 kg	36.300 kg
Operating weight	55.740 kg	55.325 kg	55.050 kg	55.900 kg	55.710 kg	54.900 kg	54.170 kg	54.180 kg	56.740 kg	

¹⁾ New shape bucket. ²⁾ Bolt-on segment edges. ³⁾ At the end of tooth or bolt-on cutting edge (B.O.C.).

All dimensions, weights, and performance values based on SAE J732c and J742b standards. Static tipping load, operating weight and overall length shown include lubricant, coolant, full fuel tank, ROPS cab and operator. Machine stability and operating weight affected by counterweight, tyre size, and other attachments.

CHANGE IN DATA CAUSED BY:

Tyres	Operating weight	Tipping load straight		Tipping load full turn		Width over tyres	Ground clearance	Overall height
		Boom 3.990 mm	Boom 3.850 mm	Boom 3.990 mm	Boom 3.850 mm			
	kg	kg	kg	kg	kg	mm	mm	mm
35/65-33-36PR (L-5)	+1000	+715	+740	+620	+640	3590	525	0
35/65-33-42PR (L-4)	+20	+10	+10	+10	+10	3605	525	0
35/65-R33 (L-4)	-780	-565	-585	-485	-500	3615	460	-65
35/65-R33 (L-5)	-235	-175	-180	-150	-150	3615	460	-65

Standard and Optional Equipment

ENGINE

Komatsu SAA6D170E-7 turbocharged common rail direct injection diesel engine	●
EU Stage IV compliant	●
Engine mode selection system: Power, Economy	●
Komatsu SmartLoader Logic	●
Adjustable auto idle shutdown	●
Auto-deceleration function	●
Fuel filter with water separator	●
Batteries 2 × 200 Ah/2 × 12 V	●

TRANSMISSION AND BRAKES

Electronically controlled ECMV automatic transmission with mode selector and variable transmission cut-off	●
Transmission shift mode selection system	●
Large-capacity torque converter	●
Torque converter lock-up	●
Variable traction control system	●
Auto-kickdown	●
Power train underguard	●
Brake cooling system (front & rear)	○

CHASSIS AND TYRES

Full floating axles	●
Front fenders	●
Bias and radial ply tyres	○
Large bore tyre valves	○

HYDRAULIC SYSTEM

2-spool main control valve	●
EPC fingertip control, two levers, including:	
- Bucket stop modulation	●
- Boom stop pre-setting	●
Automatic return-to-dig	●
Automatic digging system	●

CABIN

Spacious double door driver's cab to DIN/ISO	●
ROPS/FOPS frame according to ISO 3471/3449	●
Advanced joystick steering system	●
Heated and ventilated, high back air suspension seats with pneumatically adjustable lumbar support, console mounted height adjustable arm rests	●
3-point seat belt	●
Automatic climate control system	●
Multi-function colour monitor with Equipment Management and Monitoring System (EMMS) and efficiency guidance	●
Payload meter	●
CD radio w. auxiliary input (MP3 jack)	●
Hot and cool box	●
Heated rear window	●
Rear window wiper	●
2× 12 V power supply	●
Sun visor	●
Steering wheel with adjustable steering column	○

SERVICE AND MAINTENANCE

Hydrostat-driven radiator fan with manual reversing function	●
Modular design wide core radiator	●
In-line filters, steering and hydraulic system	●
KOMTRAX™ Plus – Komatsu wireless monitoring system	●
Komatsu CARE™ – a maintenance program for Komatsu customers	●
Tool-set	●
Automatic central lubrication	○
Provision for fast fuel fill	○

ATTACHMENTS

Boom 3.900 mm	●
Boom 3.850 mm	○
Spade nose rock buckets	○
Straight edge rock buckets	○
Special buckets on request	○

SAFETY EQUIPMENT

Emergency steering system	●
Vandalism protection	●
Back-up alarm	●
Electric horn	●
Battery main switch	●
Handrails on left/right	●
Rear access stairs	●
Rear view mirrors	●
Rear-view camera system	●
Fire extinguisher	○
Beacon light, amber color	○

LIGHTING SYSTEM

2 halogen main headlights	●
2 LED spotlights at front and rear	●
LED reversing light	●
LED stop and tail light	●
Step light	●

OTHER EQUIPMENT

Electronically controlled load stabilizer (ECSS II)	●
Counterweight 1.890 kg	●
Load & Carry specification	○
Add. counterweight for Load & Carry specification 857 kg	○
Cold area kit (engine and cab pre-heating)	○
Special custom colour	○

Further equipment on request

- standard equipment
- optional equipment

Your Komatsu partner:

KOMATSU

**Komatsu Europe
International N.V.**

Mechelsesteenweg 586
B-1800 VILVOORDE (BELGIUM)
Tel. +32-2-255 24 11
Fax +32-2-252 19 81
www.komatsu.eu

EENSS20192 04/2019

KOMATSU is a trademark of Komatsu Ltd. Japan.