

# KOMATSU

## WA80M-8

*EU Stage V Engine*

**WHEEL LOADER**



WA80

**ENGINE POWER**

53,7 kW / 72,0 HP @ 2.100 rpm

**OPERATING WEIGHT**

5.690 - 5.995 kg

**BUCKET CAPACITY**

0,8 - 1,25 m<sup>3</sup>

# Walk-Around

WA80M-8



**ENGINE POWER**

53,7 kW / 72,0 HP @ 2.100 rpm

**OPERATING WEIGHT**

5.690 - 5.995 kg

**BUCKET CAPACITY**

0,8 - 1,25 m<sup>3</sup>





## **INCREASED FUEL EFFICIENCY AND ENVIRONMENTAL PERFORMANCE**

### ***Powerful and Environmentally Friendly***

- EU Stage V engine
- High payloads and tipping loads
- Superior breakout force
- Highly efficient hydrostatic drive line
- Low operating costs

### ***First-Class Comfort***

- Quiet and ergonomic working environment
- Large multifunctional monitor
- Improved, ergonomic control elements
- Air conditioning (optional)
- Electronic Controlled Suspension System (ECSS) (optional)

### ***Total versatility***

- Easy Fork (EF) kinematic for parallel movement during fork application
- Excellent all-round visibility
- 40 km/h limited hydrostatic driveline (optional)
- 100% differential lock (optional)

### ***Easy Maintenance***

- Tilting cab
- Wide opening engine hood
- Wide core radiator with (optional) reversible fan
- Quick-access service side cover

### ***KOMTRAX***

- Komatsu Wireless Monitoring System
- 4G mobile communications
- Integrated communication antenna
- Increased operational data and fuel savings

# Powerful and Environmentally Friendly



## Full power for the highest performance

Optimised for tough construction applications, the Komatsu S4D98E-6VHA engine delivers high torque even at low rpm. With high rimpull and enough reserves even in the most difficult ground conditions the WA80M-8 still features a low fuel consumption. A fully automatic, hydrostatic transmission sends power to all four wheels while the large 110 l fuel tank guarantees long and uninterrupted working hours.

## Komatsu EU Stage V

The Komatsu EU Stage V engine is productive, dependable and efficient. With ultra-low emissions, it provides a lower environmental impact and a superior performance to help reduce operating costs. The operator can work in complete peace of mind.

## High productivity

If you're looking for a small machine with huge performances, then this compact wheel loader is made for you. With its amazing lifting and dumping height and superior breakout power, it works like a bigger machine. When equipped with one of Komatsu's redesigned, larger and easier to fill buckets, or with pallet forks, high payloads guarantee maximum productivity.

WA80M-8



## Total versatility

### Diverse and flexible

Komatsu's compact wheel loaders are an optimal choice for a wide range of applications. On construction sites, in the recycling industry or for agricultural jobs, with the hydraulic quick-coupler and a wide range of attachments, these machines are extremely versatile. When working with Komatsu pallet forks, the operator can rely on EF kinematic to transport loads parallel to the ground without readjusting the fork tines.

### A wide choice of options

On uneven grounds the optional ECSS load stabiliser reduces shocks and increases productivity and comfort. The optional 100% differential lock axles can be activated for extra traction force. A towing device is standard. Other optional equipment such as creeping function, 40 km/h limited hydrostatic driveline option, additional working lights or an immobiliser, are available on request.

### Highest safety

For maximum operational safety, the machine's low centre of gravity enhances stability, and its compact dimensions ensure exceptional all-round visibility. Standard safety features such as the ROPS/FOPS cab, back-up alarm, reversing light and large mirrors add up to make the WA80M-8 a truly safe machine.



100% manual locking differentials front and rear (option)



Electronically controlled suspension system load stabilizer (ECSS) (option)



40 km/h limited hydrostatic driveline (option)



# First-Class Comfort



## Excellent all-round visibility

Thanks to wide glass surfaces and lower door windows, the machine offers excellent visibility in all directions, for total control of the surrounding area.

*Standard heated rear window and a newly designed, low-profile exhaust pipe ensure improved rear visibility (according to ISO 5006).*



WA80M-8





### Highest operator comfort

Along with its compact size, the WA80M-8 offers unequalled comfort. The spacious cab was developed with exceptional care given to details and special attention for the ergonomic controls. Efficient air conditioning (option) and ventilation guarantee ideal thermal comfort. The wide cab door allows fast and safe entering and exiting. The work environment is quiet and comfortable thanks to optimal noise insulation.

### New multi-function monitor with more information

The user-friendly multi-function colour monitor with Equipment Management and Monitoring System (EMMS) supports safe and smooth work. Eco-gauge and an Eco guidance with active recommendations help maximising fuel savings. The monitor is conveniently customisable with a choice of 24 languages.



*Large multi-function monitor*



*Improved, ergonomic control elements*

# Easy Maintenance

## A reliable partner

Komatsu compact wheel loaders are known around the world for their robustness and durability. All maintenance and service is performed easily and quickly thanks to their unique tilting cab. The engine hood can be opened widely for a quick daily inspection, the electric equipment is well protected behind a maintenance

cover inside the cab, and the easy-to-clean radiator is conveniently accessible. A compartment for battery, main switch and relays improves maintenance access to the electrical system.



*Fast, easy and comfortable access to daily inspection points*



*Wide core radiator with (optional) reversible fan*



*Side cover for quick maintenance access*

WA80M-8



# KOMTRAX

## The way to higher productivity

KOMTRAX uses the latest wireless monitoring technology. Compatible on PC, smartphone or tablet, it delivers insightful and cost saving information about your fleet and equipment, and offers a wealth of information to facilitate peak machine performance. By creating a tightly integrated web of support it allows proactive and preventive maintenance and helps to efficiently run a business.



## Knowledge

You get quick answers to basic and critical questions about your machines – what they're doing, when they did it, where they're located, how they can be used more efficiently and when they need to be serviced.

Performance data is relayed by wireless communication technology (satellite, GPRS or 3G depending on model) from the machine to a computer and to the local Komatsu distributor – who's readily available for expert analysis and feedback.

## Power

The detailed information that KOMTRAX puts at your fingertips 24 hours a day, 7 days a week gives the power to make better daily and long-term strategic decisions – at no extra cost. Problems can be anticipated, maintenance schedules customised, downtime minimised and machines kept where they belong: working on the jobsite.

## Convenience

KOMTRAX enables convenient fleet management on the web, wherever you are. Data is analysed and packaged specifically for effortless and intuitive viewing in maps, lists, graphs and charts. You can foresee eventual maintenance issues and required spare parts, and troubleshoot a problem before Komatsu technicians arrive on site.



# Specifications

## ENGINE

Model	Komatsu S4D98E-6VHA
Type	Common rail direct injection, water-cooled, emissionised, turbocharged diesel
Engine power	
at rated engine speed	2.100 rpm
ISO 14396	53,7 kW / 72,0 HP
Max. torque/engine speed	295 Nm/1.365 rpm
No. of cylinders	4
Bore x stroke	98 x 110 mm
Displacement	3,3 l
Air-filter type	Dry air filter with pre-filter and safety cartridge

## TRANSMISSION

Drive system	Hydrostatic transmission
Hydrostatic pump	1 variable piston pump
Hydrostatic motor	1 variable piston motor
Speed ranges (forwards/backwards)	2/2
Max. travel speeds (forwards/backwards) 20 km/h version	
1. speed range	0 - 5,0 km/h
2. speed range	0 - 20,0 km/h
Creep	0 - 10,0 km/h
Max. travel speeds (forwards/backwards) 40 km/h version	
1. speed range	0 - 15 km/h
2. speed range	0 - 40 km/h
Creep	0 - 10 km/h

## CHASSIS AND TYRES

Type	Low build rear axle oscillation for optimum stability and for best performance in earthmoving applications
System	4-wheel drive
Axles	Planetary rigid axles with automatic limited slip differentials in both axles 100% locking differentials as option
Oscillation	Rear axle oscillation for optimum stability, oscillation angle 10°
Tyres	405/70 R18

## SERVICE REFILL CAPACITIES

Cooling system	9,6 l
Fuel tank	110 l
Engine oil	10,5 l
Hydraulic system	45 l
Front axle	9,1 l
Rear axle	6,0 l
Transfer (20 km/h / 40 km/h)	0,7 / 1,8 l

## BRAKES

Operating brakes	Combined inch brake pedal actuates maintenance free wet-disc type brakes in the front axle. Self-braking via the hydrostatic drive
Parking brake	Dry disc

## HYDRAULIC SYSTEM

System	Open hydraulic system
Working pressure (max.)	270 bar
Maximum pump flow	60 l/min
No. of boom/bucket cylinders	2/1
Type	Double-action
Bore diameter x stroke	
Boom cylinder	70 x 658 mm
Bucket cylinder	90 x 450 mm
Hydraulic control lever	Multifunction lever
Hydraulic cycle with rated load bucket filling	
Raise time	4,9 s
Lowering time (empty)	2,8 s
Dumping time	1,0 s

## STEERING SYSTEM

System	Articulated frame steering
Type	Hydraulic
Steering angle to either side	42°
Steering pump	Gear pump
Working pressure	185 bar
No. of steering cylinders	1
Type	Double-action
Bore diameter x stroke	70 x 378 mm
Smallest turn (outer edge of tyre 405/70 R18)	3.875 mm

## CABIN

Cabin in conformity with ISO 3471 with ROPS (roll over protective structure) in conformity with SAE J1040c and FOPS (falling object protective structure) in conformity with ISO 3449. The pressurised cabin is mounted upon rubber bearings and is noise dampened. Tilttable for best servicing access.

## ENVIRONMENT

Engine emissions	Fully complies with EU Stage V exhaust emission regulations
Noise levels	
LwA external	101 dB(A) (2000/14/EC Stage II)
LpA operator ear	74 dB(A) (ISO 6396 dynamic test)
Vibration levels (EN 12096:1997)	
Hand/arm	≤ 2,5 m/s <sup>2</sup> (uncertainty K = 0,42 m/s <sup>2</sup> )
Body	≤ 0,5 m/s <sup>2</sup> (uncertainty K = 1,19 m/s <sup>2</sup> )
Contains fluorinated greenhouse gas HFC-134a (GWP 1430). Quantity of gas 1,2 kg, CO <sub>2</sub> equivalent 1,72 t.	



# Dimensions & Performance Figures

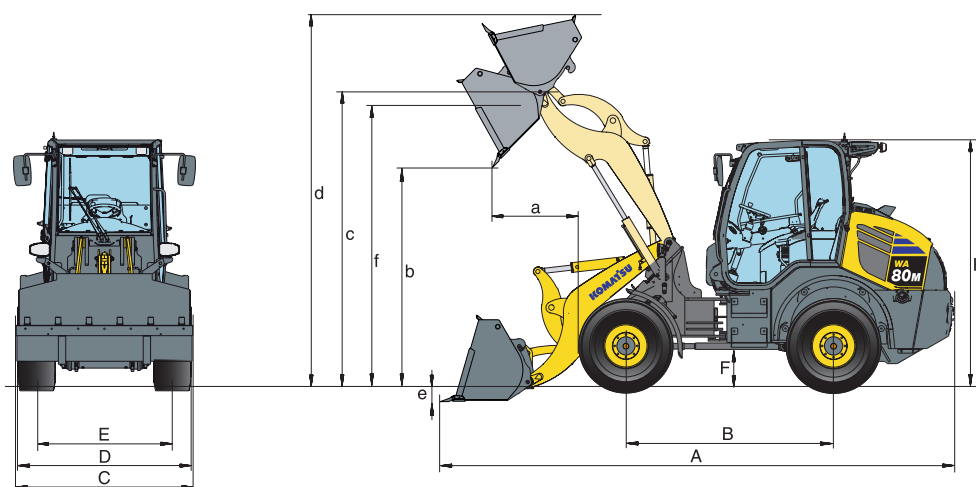

## MEASUREMENTS AND WORKING SPECIFICATIONS

		Universal		Light materials	4-in-1
		w. teeth	w/o teeth	w/o teeth	w. teeth
<b>Bucket capacity (heaped, ISO 7546)</b>	<b>m<sup>3</sup></b>	<b>1,0</b>	<b>1,0</b>	<b>1,25</b>	<b>0,8</b>
Material density	t/m <sup>3</sup>	1,8	1,8	1,25	1,8
Bucket weight	kg	330	305	335	590
Static tipping load, straight	kg	4.710	4.740	4.675	4.395
Static tipping load, 40° articulated	kg	3.965	3.990	3.930	3.630
Break-out force hydraulic	kN	50,0	50,0	37,2	47,5
Lifting capability hydr. at ground level	kN	51,0	51,0	38,4	48,6
Operating weight	kg	5.715	5.690	5.720	5.995
Turning radius at corner of tyres	mm	3.875	3.875	3.875	3.875
Turning radius at bucket edge	mm	4.290	4.290	4.440	4.315
a Reach at 45°	mm	970	875	1.015	1.050
b Dump height at 45°	mm	2.460	2.555	2.365	2.380
c Hinge pin height	mm	3.230	3.230	3.230	3.230
d Height top edge of bucket	mm	4.125	4.100	4.170	4.010
e Digging depth	mm	100	100	135	100
f Max. loading height at 45°	mm	3.030	3.030	2.990	3.030
A Overall length, bucket grounded	mm	5.625	5.495	5.750	5.730
B Wheelbase	mm	2.260	2.260	2.260	2.260
C Bucket width	mm	1.915	1.915	1.870	1.900
D Width over tyres	mm	1.825	1.825	1.825	1.825
E Track width	mm	1.440	1.440	1.440	1.440
F Ground clearance	mm	470	470	470	470
H Overall height	mm	2.750	2.750	2.750	2.750

## PERFORMANCE FIGURES WITH FORK TINES

Fork tine type		FEM IIA	FEM IIB
<b>Fork tine length</b>	<b>mm</b>	<b>1.200</b>	<b>1.200</b>
g Max. reach at ground level	mm	770	870
h Max. reach	mm	1.340	1.340
j Max. reach at max. stacking height	mm	640	640
k Max. height fork-carrier	mm	3.685	3.685
l Hinge pin height	mm	3.230	3.230
m Max. stacking height	mm	3.105	2.980
n Height of forks at maximum reach	mm	1.510	1.385
Max. tipping load, straight	kg	3.535	3.530
Max. tipping load, articulated	kg	3.000	2.975
Max. payload as per EN 474-3, 80%	kg	2.400	2.380
Max. payload as per EN 474-3, 60%	kg	1.800	1.785
Weight in working order with fork tines	kg	5.545	5.550

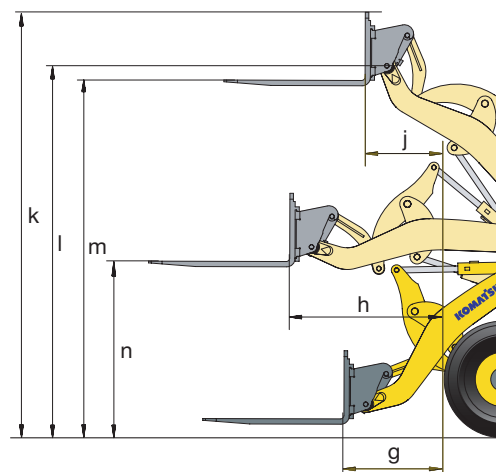

All measurements with tyres 405/70 R20 and air conditioning

# Standard and Optional Equipment

## ENGINE

Komatsu S4D98E-6VHA turbocharged common rail direct injection diesel engine	●
EU Stage V compliant	●
Diesel Particulate Filter (DPF)	●
Alternator 126 A/12 V	●
Starter motor 2,2 kW/12 V	●
Battery 100 Ah/12 V	●

## TRANSMISSION AND BRAKES

Combined inch/brake pedal	●
Creeping function (20 km/h version)	○
Creeping function (40 km/h version)	○
20 km/h limited hydrostatic driveline	○
40 km/h limited hydrostatic driveline	○

## CHASSIS AND TYRES

Heavy-duty axles	●
LSD-differential front and rear	●
100% manual locking differentials front and rear	○
Various tyre types and sizes on request	○

## HYDRAULIC SYSTEM

3-spool main control valve	●
Multi-function lever	●
Hydraulic quick-coupler	●
Loader control with return-to-dig	○
Auto-inch valve	○
Biodegradable oil for hydraulic system	○

## CABIN

Spacious double door driver's cab to DIN/ISO with heating	●
Tilting cab	●
ROPS/FOPS frame according to SAE	●
All-round tinted glazing	●
Heated rear window	●
Rear window wiper	●
Sun visor	●
Adjustable steering column	●
Suspended seat	●
Seat belt (EU standard)	●
Wrist rest with integrated small storage box	●
Large storage box at left hand side	●
Multi-function colour monitor with Equipment Management and Monitoring System (EMMS) and efficiency guidance	●
12 Volt power supply	●
Front window wiper with intermittent feature	●
Adjustable high comfort air suspension seat	○
Air conditioning	○
Radio	○
Sun reflection decal for cab/canopy roof	○

## SAFETY EQUIPMENT

Emergency steering system	●
Back-up alarm	●
Horn	●
Emergency engine stop switch	●
Seat belt caution indicator	●
Battery main switch	●
Beacon light	○
Immobiliser	○
Immobiliser with master key	○
Anti-drop valve	○
Fire extinguisher	○

## SERVICE AND MAINTENANCE

KOMTRAX – Komatsu wireless monitoring system	●
Tool-set	●
Wide-core radiator	●
Radiator fan with reversing function	○

## LIGHTING SYSTEM

Halogen headlights	●
Reversing lights	●
Additional lights front and rear	○
LED headlights	○
Optical back-up alarm (strobe light)	○

## OTHER EQUIPMENT

Z-bar boom (parallel movement when using dedicated fork tines)	●
Counterweight	●
Towing device	●
Electronically controlled suspension system load stabilizer (ECSS)	○
Special custom colour	○
Bucket level indicator	○

## ATTACHMENTS

Bucket with or without teeth	○
4-in-1 bucket	○
Light material buckets	○
Fork carrier and tines	○
Cutting edge guard	○

The WA80M-8 is equipped in accordance with the safety regulations of the machinery guidelines 89/392 EWG ff and EN474.

- standard equipment
- optional equipment

Your Komatsu partner:

# KOMATSU

**Komatsu Europe  
International N.V.**

Mechelsesteenweg 586  
B-1800 VILVOORDE (BELGIUM)  
Tel. +32-2-255 24 11  
Fax +32-2-252 19 81  
[www.komatsu.eu](http://www.komatsu.eu)

VENSS07100 05/2020

**KOMATSU** is a trademark of Komatsu Ltd. Japan.