

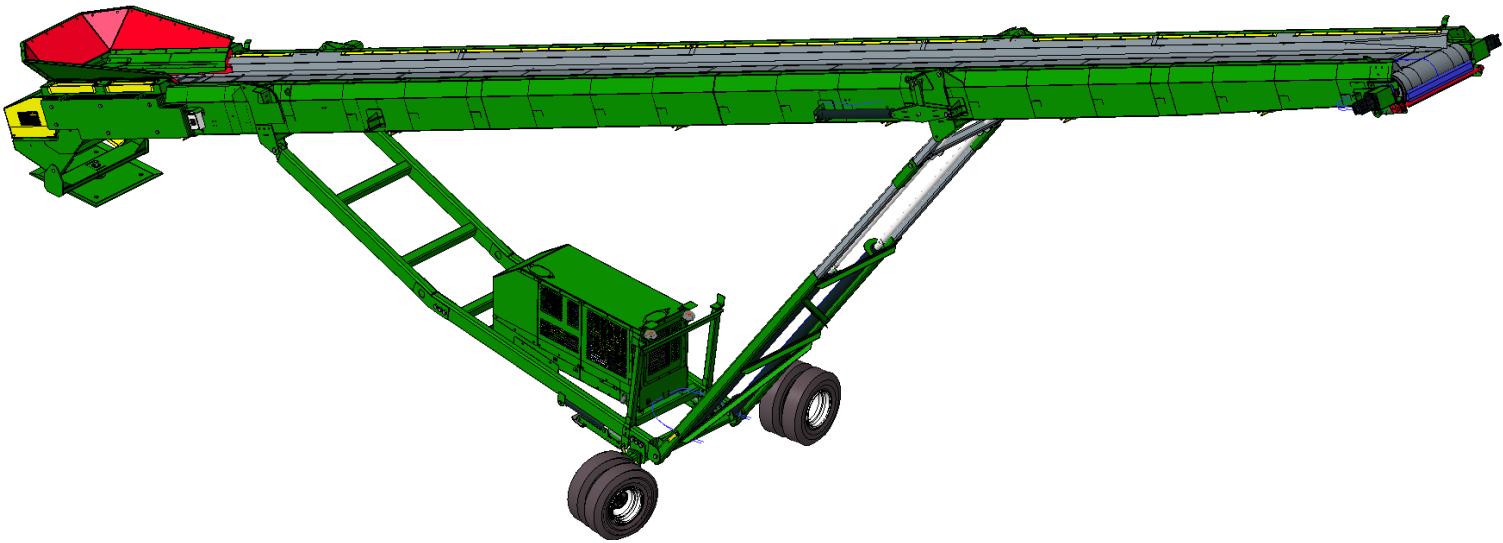

SPECIFICATIONS



WS4080

WHEELED MOBILE CONVEYOR

Optional equipment may be shown



DESCRIPTION

The newly designed WS4080 is McCloskey international's newest addition to the materials handling division. Designed to allow operators to stockpile/transfer material directly from existing McCloskey mobile crushing and screening plants it offers a low cost solution to all your material handling needs. It offers the flexibility and mobility needed to ensure that the stockpiling process is as fast and efficient as possible, it eliminates the use of a loader and also the double handling of materials.

The unit can also be containerized for transport (2 per high cube open top container), substantially reducing transport costs.

The WS4080 wheeled mobile Conveyor comes with the following features as standard:

- Hydraulic main drive system.
- Hydraulic folding heading section for transport minimizing setup time.
- Hydraulically adjustable discharge height up to 10.5 meters
- 1000mm (40") wide belt capacity
- Rear heavy duty radial pivot stand and on site tow bar
- Fuel efficient Hydraulics system.
- Fully skirted feed boot section.
- Hopper Hardox Plates
- Impact bed under feed boot
- User Friendly Hydraulic Controls.
- ISUZU 4LE1 50HP as standard, closed coupled and electric available.

DIMENSIONS AND CAPACITIES

Length – working (Max)	23.5m (77'-3")
Height – working (Max)	10.8m (35'-5")
Length – transport	16.33m (53'-7")
Width – transport	3.35m (11'-0")
Height – transport	3.56m (11'-8")
Over Hang - Transport	5.44m (17'-10")
Maximum Production Rate	400 MTPH (460 TPH)
Max Product Size	300MM (12") minus

MATERIALS

Materials include but are not limited to;

- Sand and Gravel
- Aggregates
- Compost
- Topsoil
- C and D waste
- Mulch
- Coal



CONVEYOR

Belt width	1000mm (40")
Belt spec	3 Ply (400/3 5+1.5)
Scraper	Urethane scraper as standard
Pulley Adjuster	Standard Threaded Bar
Conveyor Idlers	45 Degree angle
Return Idlers	Self-Cleaning Rubber Disc
Conveyor motor	SINGLE DANFOSS OMOV630
Drive Drum	350mm Ø with diamond Lagging
Tail Drum	270mm Ø spoked drum

Capacities

Hydraulic tank	218 L (57 US gal)
Diesel Tank	95 L (25 US gal)
Feeder Boot Capacity	1.1M ³ (1.4 Yd ³)

OPTIONS INCLUDING BUT NOT LIMITED TO;

- Electric Drive.
- Feed boot Rubber Liners.
- Head Scraper upgrade.
- Anti-Roll backs
- Auto Radial wheel drive (Hub Drive)
- Radial Axle Jack legs
- Extended Feed boot with crash Box.
- Radio remote control Conveyor and setup functions.
- Full conveyor skirting
- Heavy duty 4 ply belt

SAFETY FEATURES

- External belt alignment points.
- External grease points.
- Engine safety shutdown systems.
- Full safety guarding for nip points.

WS4080

FEB.2019.issue 004

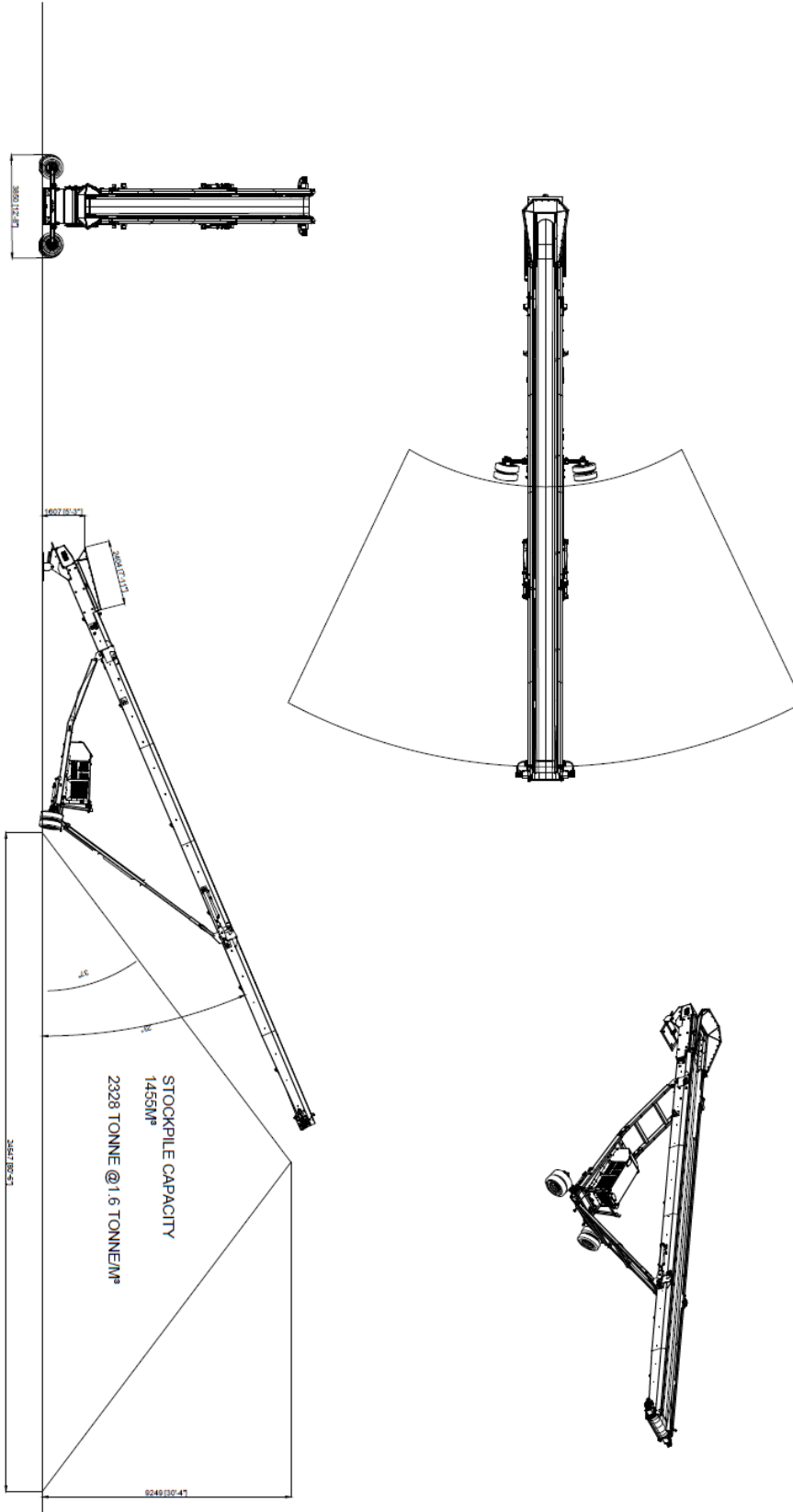

WS4080

FEB.2019.issue 004

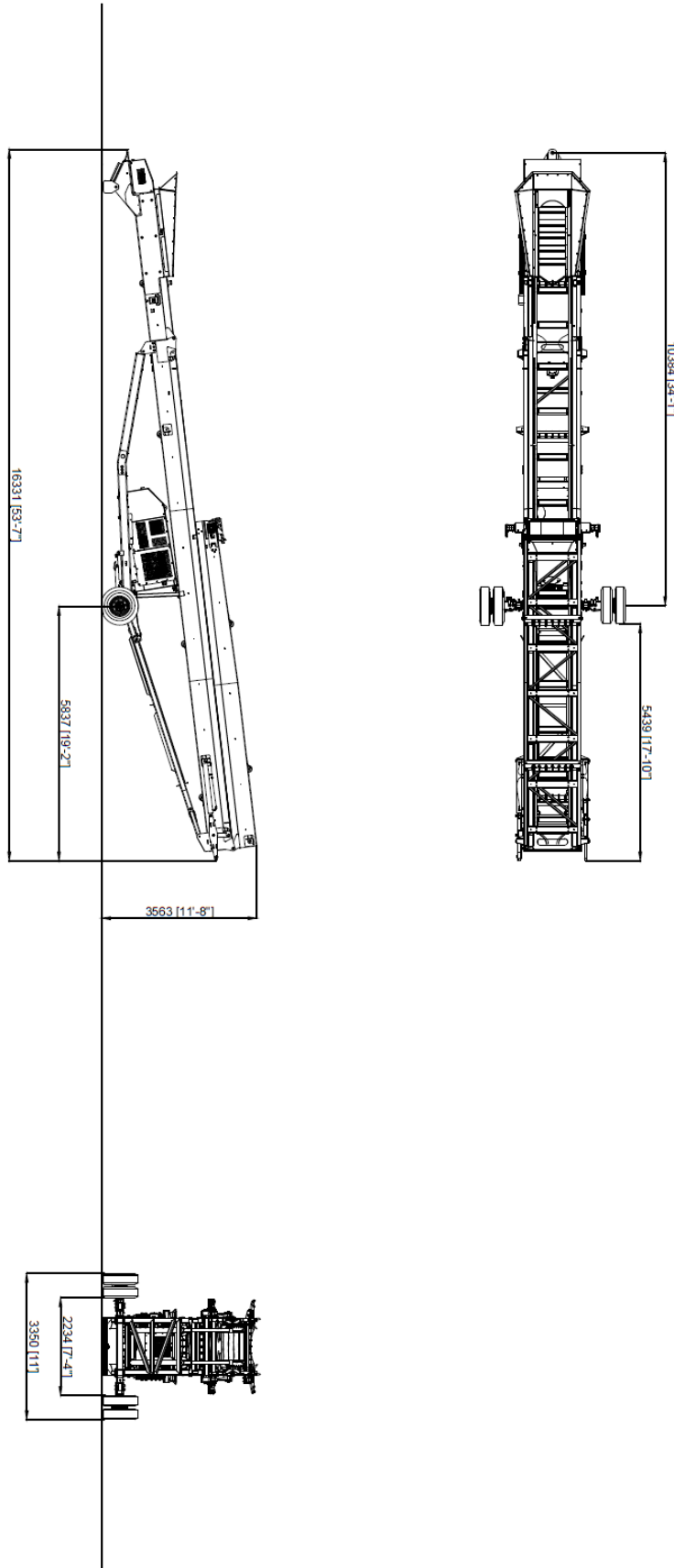

WS4080

FEB.2019.issue 004

